



CORIAN[®]
DESIGN



CORIAN[®] SOLID SURFACE

**SPECIFICATION TOOL
FOR ARCHITECTS & DESIGNERS**



Dear Specifier,

Thank you for selecting Corian® Solid Surface for the specification of your project.

In this document, we will present a sample specification for Solid Surfacing fabrications of Corian® Solid Surface for commercial applications requested for tenders.

This sample specification details the furnishing and installation of Corian® Solid Surface fabrications of monolithic mineral filled polymer consisting of, but not limited to, sheet work, basins, sinks, coved detail work, colour inlay work and thermoforming.

Please use this specification document as a copy and paste tool to enable creation of your own project specification with Corian® Solid Surface.

Kind Regards

Corian® Design EMEA Technical Marketing Team



INDEX

INSTRUCTIONS FOR USING THIS ACTIVE DOCUMENT

GENERAL CORIAN® INFORMATION

- CORIAN® SHEET SIZES AND COLOURS
- CORIAN® SINKS
- CORIAN® BASINS
- CORIAN® BATHS
- CORIAN® SHOWERTRAYS
- CORIAN® USEFUL PRODUCT LINKS

SPECIFIC APPLICATIONS

- KITCHEN WORKTOPS, ISLANDS AND WORKTOPS WITH SINKS
- VANITY TOPS
- RECEPTION AREA STATIONS
- LABORATORY AND HOSPITAL WORKTOPS
- TABLETOPS AND BAR TOPS
- COLD AND HOT COMMERCIAL FOOD SERVICES COUNTERS
- INTERIOR WALL CLADDING
- INTERIOR WINDOW SILLS
- SHOWER WALLS
- EXTERIOR CLADDING

ADDITIONAL FEATURES

- COVERED AND SQUARE UPSTAND OR BACKSPLASH
- INLAYS
- ENGRAVING
- BACKLIGHTING
- THERMOFORMING
- EDGE DETAIL EXAMPLES
- UPSTAND AND BACKSPLASH EXAMPLES

ANNEXES (Example Drawings)

- KITCHEN WORKTOPS, ISLANDS AND WORKTOPS WITH SINKS
- RECEPTION AREA STATIONS
- LABORATORY AND HOSPITAL WORKTOPS
- VANITY TOPS
- TABLETOPS



INSTRUCTIONS FOR USING THIS ACTIVE DOCUMENT

This document is intended as a useful specification building tool for creating specifications with Corian® Solid Surface.

To use this document the active title links in the Index or the navigation buttons in the ribbon on the right hand side can be selected to find appropriate content to copy and paste into your specification.

Within the sections of text are options indicated with **[brackets]** for inclusion or deletion where relevant.

The **General Corian® Information** link provides broad information about Corian® Solid Surface to add at the beginning of the specification or for reference purposes.

Following the General Corian® Information section the relevant Corian® product information can be used for reference and selected if required to be added into your specification regarding nominal sheet sizes, thicknesses and other Corian® products, for example sinks.

The **Applications** section provides useful template text for creating specifications in common applications, for example for kitchen worktops, receptions or vanity worktops.

The additional features text can be added to your specification text if for example a worktop requires a coved detail or an inlay.

The **Edge details** link provides examples of common edge detail designs for Corian® worktops.

The **Upstand and Backsplash** examples link provides useful diagrams for this aspect.

The final section of **Annexes** provides example design drawings and views for inspiration related to a variety of applications.



GENERAL CORIAN® INFORMATION

Corian® Solid Surface is a nonporous, homogeneous material maintaining the same composition throughout the sheet with a composition of 1/3 Acrylic polymer, 2/3 Aluminium trihydrate filler and pigments.

Manufacturer: Corian® Solid Surface material by DuPont™; www.corian.com

Thicknesses: 12 mm, (4mm, 6 mm and 19 mm for specific applications)

Finish: Provide Corian® with uniform finish characteristics: [Matte] [Semi-Gloss][Gloss]

Note: Higher gloss levels require additional processing steps.

All machined panel features should include minimum radius of 1.5mm to the top and bottom sheet edges.

Larger panel sizes: Seams in applications where more strength/heavy loads are placed on the surface must be reinforced with 50 mm wide reinforcement strip of 12 mm thick (6 mm if for vertical use sheet used is 6 mm) Corian® Solid Surface. Reinforcement strip must be fully bonded with Corian® Joint Adhesive.

Corian® colours containing random veins: Veins may vary in intensity and highlight seams. Sample may not represent the full aesthetic. Ask your Corian® sales contact for samples and more detailed information.

Thermoform panels in shapes as indicated in drawings.

Be aware of Corian® “Use & Care” information to keep the installation in a good shape, choose lighter and/or particulate colours to hide heavy usage on the sheet. For heavy use areas such as kitchen worktops, Corian® colours should be selected from the Corian® Kitchen Colours list, please discuss with your Corian® sales representative.

Corian® Colour: [COLOUR NAME]

Lightfastness: no colour change with all colours in interior applications.

Fire rating: Please discuss with your Corian® sales representative regarding availability of colours for the required fire rating.

Warranty: DuPont™ protection for Corian® Solid Surface: on product level and on installation level.

The product warranty is standard for Corian® Solid Surface sheets, sinks and basins manufactured by DuPont™, and ensures that they will be free of manufacturing defects for a period of 10 years after purchase.

A higher level of coverage, the Limited Installed Warranty, is only available when fabrication and installation are carried out by a Corian® Quality Network™ Industrial Partner. This Limited Installed Warranty expands the product warranty and ensures that fabrication and installation of the finished product will be free of defects.



CORIAN® SHEET SIZES AND COLOURS

SHEET SIZE	AVAILABLE COLOURS
4 X 930 X 2490 mm (VERTICAL USE ONLY)	[Glacier White]
6 X 760 X 2490 mm (VERTICAL USE ONLY)	[Bisque] [Bone] [Cameo White] [Designer White] [Glacier Ice] [Glacier White] [Vanilla]
6 X 930 X 2490 mm (VERTICAL USE ONLY)	[Cameo White] [Glacier White]
6 X 1300X2490 mm (VERTICAL USE ONLY)	[Glacier White]
12 X 760 X 3658 mm (HORIZONTAL & VERTICAL USE)	[Abalone] [Antarctica] [Arctic Ice] [Arrowroot] [Artista Beige] [Artista Canvas] [Artista Dust] [Artista Gray] [Ash Aggregate] [Ash Concrete] [Aspen] [Aurora] [Bisque] [Bleached Nuwood] [Bone] [Cameo White] [Carbon Aggregate] [Carbon Concrete] [Carrara Crema] [Carrara Lino] [Clam Shell] [Cosmos Prima] [Designer White] [Domino Terrazzo] [Dove] [Dune Prima] [Elegant Gray] [Evening Prima] [Everest] [Glacier Ice] [Glacier White] [Gray Onyx] [Hazelnut] [Hot] [Juniper] [Laguna] [Lava Rock] [Light Ash] [Limestone Prima] [Linen] [Matterhorn] [Neutral Aggregate] [Neutral Concrete] [Nimbus Prima] [Pearl Gray] [Platinum] [Provence Nuwood] [Rain Cloud] [Rosemary] [Sagebrush] [Sahara] [Salt] [Sand Storm] [Sandalwood] [Savannah] [Sepia Linear] [Silt] [Silver Birch] [Silver Gray] [Silver Linear] [Smoke Drift Prima] [Sparkling Granita] [Sparkling White] [Vanilla] [Venaro White] [Verdant] [Weathered Aggregate] [Weathered Concrete] [White Jasmine] [White Onyx] [Willow] [Windswept Prima] [Witch Hazel]
12 X 930 X 3658 mm (HORIZONTAL & VERTICAL USE)	[Cameo White] [Glacier White]
12 X 1300 X 3658 mm (HORIZONTAL & VERTICAL USE)	[Cameo White] [Designer White] [Glacier White]
12 X 1500 X 3658 mm (HORIZONTAL & VERTICAL USE)	[Glacier White]
19 X 760 X 3658 mm (HORIZONTAL USE ONLY)	[Glacier White]

For more information and visuals of Corian® colours visit: www.corian.uk/-colours-of-corian-r-



CORIAN® SHEET SIZES AND COLOURS

DEEP COLOUR™ TECHNOLOGY

Through Deep Colour™ Technology (DCT) richer, darker colours allow designers, architects and fabricators to achieve tones they never thought were possible using Corian® Solid Surface.

Corian® Deep Colour™ Technology material retains depth of colour, enabling designers and fabricators to create curves and shapes in dark tones that were not previously possible.

SHEET SIZE	AVAILABLE COLOURS
6 X 760 X 2490 mm (VERTICAL USE ONLY)	[Deep Nocturne]
12 X 760 X 3658 mm (HORIZONTAL & VERTICAL USE)	[Deep Anthracite] [Deep Black Quartz] [Deep Cloud] [Deep Espresso] [Deep Mink] [Deep Night Sky] [Deep Nocturne] [Deep Sable] [Deep Storm] [Deep Titanium]

COLOURS RECOMMENDED FOR KITCHEN WORKTOPS AND HEAVY USE ENVIRONMENTS

These colours are suitable for applications in kitchen and other environments with intense and heavy use, as only less noticeable marks may appear and be visible under specific lighting conditions.

SHEET SIZE	AVAILABLE COLOURS
12 X 760 X 3658 mm (HORIZONTAL & VERTICAL USE)	[Abalone] [Antarctica] [Arctic Ice] [Arrowroot] [Artista Canvas] [Artista Gray] [Ash Aggregate] [Aspen] [Aurora] [Bisque] [Bone] [Cameo White] [Carbon Aggregate] [Carrara Crema] [Carrara Lino] [Clam Shell] [Cosmos Prima] [Deep Black Quartz] [Deep Night Sky] [Designer White] [Domino Terrazzo] [Dove] [Dune Prima] [Elegant Gray] [Everest] [Glacier White] [Gray Onyx] [Hazelnut] [Juniper] [Lava Rock] [Light Ash] [Limestone Prima] [Linen] [Matterhorn] [Neutral Concrete] [Nimbus Prima] [Pearl Gray] [Platinum] [Rain Cloud] [Rosemary] [Sagebrush] [Sahara] [Salt] [Sand Storm] [Sandalwood] [Savannah] [Sepia Linear] [Silt] [Silver Birch] [Silver Gray] [Silver Linear] [Sparkling Granita] [Sparkling White] [Vanilla] [Venaro White] [Weathered Aggregate] [White Jasmine] [White Onyx] [Willow] [Witch Hazel]

For more information and visuals of Corian® colours visit: www.corian.uk/-colours-of-corian-r-



CORIAN® SINKS

DIMENSIONS: L x W x D (mm)

SINK MODEL / INTERNAL SIZE	COLOUR	OVERFLOW
 <p>SMOOTH – 850 736 X 425 X 228 mm</p>	<p>[Glacier White] [Cameo White] [Designer White]</p>	FRONT OVERFLOW ALL COLOURS
 <p>SWEET – 804 399 X 399 X 208 mm</p>	<p>[Glacier White] [Cameo White] [Designer White]</p>	<p>WITH OR WITHOUT OVERFLOW FRONT OVERFLOW FRONT OVERFLOW</p>
 <p>SWEET – 805 400 X 451 X 211 mm</p>	<p>[Glacier White] [Cameo White] [Designer White]</p>	FRONT OVERFLOW ALL COLOURS
 <p>SWEET – 809 267 X 320 X 170 mm</p>	<p>[Glacier White] [Cameo White] [Designer White]</p>	FRONT OVERFLOW ALL COLOURS
 <p>SWEET – 857 152 X 299 X 146 mm</p>	<p>[Glacier White] [Cameo White] [Designer White]</p>	FRONT OVERFLOW ALL COLOURS
 <p>SWEET – 859 440 X 339 X 200 mm</p>	<p>[Glacier White] [Cameo White] [Designer White]</p>	<p>FRONT OVERFLOW OVERFLOW FRONT OVERFLOW FRONT OVERFLOW</p>

For additional information and visuals visit: www.corian.uk/-the-complete-residential-surfaces-solutions-

For technical diagrams and 3D models please visit: www.corian.uk/IMG/pdf/emea_technical_drawings.pdf









SINK MODEL / INTERNAL SIZE	COLOUR	OVERFLOW
 <p>SWEET – 871 530 X 397 X 187 mm</p>	[Glacier White]	WITH OR WITHOUT OVERFLOW
	[Cameo White]	FRONT OVERFLOW
	[Designer White]	FRONT OVERFLOW
 <p>SWEET – 881 690 X 431 X 216 mm</p>	[Glacier White] [Cameo White] [Designer White]	FRONT OVERFLOW ALL COLOURS
 <p>SPICY – 965 400 X 400 X 174 mm</p>	[Glacier White] [Cameo White] [Designer White]	FRONT OVERFLOW ALL COLOURS
 <p>SPICY – 966 700 X 400 X 174 mm</p>	[Glacier White] [Cameo White] [Designer White]	FRONT OVERFLOW ALL COLOURS
 <p>SPICY – 967 160 X 350 X 140 mm</p>	[Glacier White] [Cameo White] [Designer White]	FRONT OVERFLOW ALL COLOURS
 <p>SPICY – 969 330 X 400 X 175 mm</p>	[Glacier White] [Cameo White] [Designer White]	FRONT OVERFLOW ALL COLOURS

For additional information and visuals visit: www.corian.uk/-the-complete-residential-surfaces-solutions-

For technical diagrams and 3D models please visit: www.corian.uk/IMG/pdf/emea_technical_drawings.pdf



SINK MODEL / INTERNAL SIZE	COLOUR	OVERFLOW
 <p>SPICY – 970 530 X 400 X 175 mm</p>	<p>[Glacier White] [Cameo White] [Designer White]</p>	<p>FRONT OVERFLOW ALL COLOURS</p>
 <p>SPICY – 9910 200 X 400 X 176 mm</p>	<p>[Glacier White] [Designer White]</p>	<p>FRONT OVERFLOW ALL COLOURS</p>
 <p>SPICY – 9920 952 X 400 X 176 mm Bowl: 500 X 400 X 176 mm</p>	<p>[Glacier White] [Designer White]</p>	<p>FRONT OVERFLOW ALL COLOURS</p>
 <p>SALTY – 9410 800 X 400 X 176 mm</p>	<p>[Glacier White] [Designer White]</p>	<p>FRONT OVERFLOW ALL COLOURS</p>
 <p>TASTY – 9610 630 X 500 X 196 mm Bowl: 630 X 400 X 196 mm</p>	<p>[Glacier White] [Designer White]</p>	<p>FRONT OVERFLOW ALL COLOURS</p>
 <p>ROUNDED – 9310 Dia 450 X 176 mm</p>	<p>[Glacier White] [Designer White]</p>	<p>FRONT OVERFLOW ALL COLOURS</p>







For additional information and visuals visit: www.corian.uk/-the-complete-residential-surfaces-solutions-

For technical diagrams and 3D models please visit: www.corian.uk/IMG/pdf/emea_technical_drawings.pdf



CORIAN® BASINS

DIMENSIONS: L x W x D (mm)

BASIN MODEL / INTERNAL SIZE	COLOUR	OVERFLOW
 <p>CALM – 810 419 X 333 X 138 mm</p>	[Glacier White]	WITH/WITHOUT/REAR OPTION
	[Cameo White]	WITH/WITHOUT/REAR OPTION
	[Designer White]	FRONT OVERFLOW
 <p>CALM – 815 521 X 368 X 158 mm</p>	[Glacier White]	WITH/WITHOUT/ OPTION
	[Cameo White]	FRONT OVERFLOW
	[Designer White]	FRONT OVERFLOW
 <p>CALM – 820 373 X 266 X 139 mm</p>	[Glacier White]	WITH/WITHOUT/ OPTION
	[Cameo White]	FRONT OVERFLOW
	[Designer White]	FRONT OVERFLOW
 <p>PURITY – 7210 Dia 350 X 130 mm</p>	[Glacier White] [Designer White]	FRONT OVERFLOW ALL COLOURS
 <p>PURITY – 7220 Dia 400 X 140 mm</p>	[Glacier White] [Designer White]	FRONT OVERFLOW ALL COLOURS
 <p>RELAX – 7310 420 X 330 X 120 mm</p>	[Glacier White] [Designer White]	FRONT OVERFLOW ALL COLOURS

For additional information and visuals visit: www.corian.uk/-the-complete-residential-surfaces-solutions-

For technical diagrams and 3D models please visit: www.corian.uk/IMG/pdf/emea_technical_drawings.pdf







BASIN MODEL / INTERNAL SIZE	COLOUR	OVERFLOW
 <p>RELAX – 7320 465 X 340 X 131 mm</p>	<p>[Glacier White] [Designer White]</p>	<p>FRONT OVERFLOW ALL COLOURS</p>
 <p>RELAX – 7330 515 X 350 X 140 mm</p>	<p>[Glacier White] [Designer White]</p>	<p>FRONT OVERFLOW ALL COLOURS</p>
 <p>REFRESH – 7410 450 X 320 X 120 mm</p>	<p>[Glacier White] [Designer White]</p>	<p>FRONT OVERFLOW ALL COLOURS</p>
 <p>REFRESH – 7420 500 X 320 X 129 mm</p>	<p>[Glacier White] [Designer White]</p>	<p>FRONT OVERFLOW ALL COLOURS</p>
 <p>SERENITY – 7510 370 X 370 X 120 mm</p>	<p>[Glacier White] [Designer White]</p>	<p>FRONT OVERFLOW ALL COLOURS</p>
 <p>SERENITY – 7520 470 X 320 X 130 mm</p>	<p>[Glacier White] [Designer White]</p>	<p>FRONT OVERFLOW ALL COLOURS</p>

For additional information and visuals visit: www.corian.uk/-the-complete-residential-surfaces-solutions-

For technical diagrams and 3D models please visit: www.corian.uk/IMG/pdf/emea_technical_drawings.pdf





BASIN MODEL / INTERNAL SIZE	COLOUR	OVERFLOW
 <p>SERENITY – 7530 520 X 320 X 130 mm</p>	<p>[Glacier White] [Designer White]</p>	<p>FRONT OVERFLOW ALL COLOURS</p>
 <p>PEACE – 7610 540 X 320 X 120 mm</p>	<p>[Glacier White] [Designer White]</p>	<p>FRONT OVERFLOW ALL COLOURS</p>
 <p>ENERGY – 7710 440 X 300 X 120 mm</p>	<p>[Glacier White] [Designer White]</p>	<p>FRONT OVERFLOW ALL COLOURS</p>
 <p>ENERGY – 7720 490 X 310 X 130 mm</p>	<p>[Glacier White] [Designer White]</p>	<p>FRONT OVERFLOW ALL COLOURS</p>
 <p>ENERGY – 7730 540 X 320 X 130 mm</p>	<p>[Glacier White] [Designer White]</p>	<p>FRONT OVERFLOW ALL COLOURS</p>
 <p>QUIET – 7110 450 X 300 X 110 mm</p>	<p>[Glacier White] [Designer White]</p>	<p>FRONT OVERFLOW ALL COLOURS</p>

For additional information and visuals visit: www.corian.uk/-the-complete-residential-surfaces-solutions-

For technical diagrams and 3D models please visit: www.corian.uk/IMG/pdf/emea_technical_drawings.pdf



BASIN MODEL / INTERNAL SIZE	COLOUR	OVERFLOW
 QUIET – 7120 550 X 320 X 110 mm	[Glacier White] [Designer White]	FRONT OVERFLOW ALL COLOURS
 CARE – 5310 620 X 400 X 160 mm	[Glacier White]	FRONT OVERFLOW
 CARE – 5510 451 X 345 X 85 mm	[Glacier White]	FRONT OVERFLOW

For additional information and visuals visit: www.corian.uk/-the-complete-residential-surfaces-solutions-

For technical diagrams and 3D models please visit: www.corian.uk/IMG/pdf/emea_technical_drawings.pdf



CORIAN® BATHS

DIMENSIONS: L x W x D (mm)

MODEL / SIZE		COLOUR
	8410* Internal 1630 X 650 X 440 mm Overall 2030 X 1050 X 545 mm	[Delight White]
	8420* Internal 1650 X 650 X 440 mm Overall 2050 X 1050 X 545 mm	[Delight White]
	8430* Overall 1700 X 804 X 500 mm	[Delight White]

*Made with AMP - Acrylic Modified Polyester

For additional information and visuals visit: www.corian.uk/-shower-trays-and-baths-

For technical diagrams and 3D models please visit: www.corian.uk/IMG/pdf/emea_technical_drawings.pdf



CORIAN® SHOWER TRAYS

All CORIAN® Smart shower trays are available in colour: [\[Glacier White\]](#)



DIMENSIONS: L x W x D (mm)

MODEL	OVERALL DIMENSION (mm)	RECESSED AREA (mm)
8211	800 X 1200 X 30	700 X 700
8212	800 X 1200 X 30	700 X 1100
8213	800 X 1400 X 30	700 X 1100
8214	800 X 1600 X 30	700 X 1100
8215	800 X 1800 X 30	700 X 1100
8216	800 X 2000 X 30	700 X 1100
8221	900 X 1200 X 30	800 X 800
8222	900 X 1200 X 30	800 X 1100
8223	900 X 1400 X 30	800 X 1100
8224	900 X 1600 X 30	800 X 1100
8225	900 X 1800 X 30	800 X 1100
8226	900 X 2000 X 30	800 X 1100

For additional information and visuals visit: www.corian.uk/-shower-trays-and-baths-

For technical diagrams and 3D models please visit: www.corian.uk/IMG/pdf/emea_technical_drawings.pdf



CORIAN® USEFUL PRODUCT LINKS

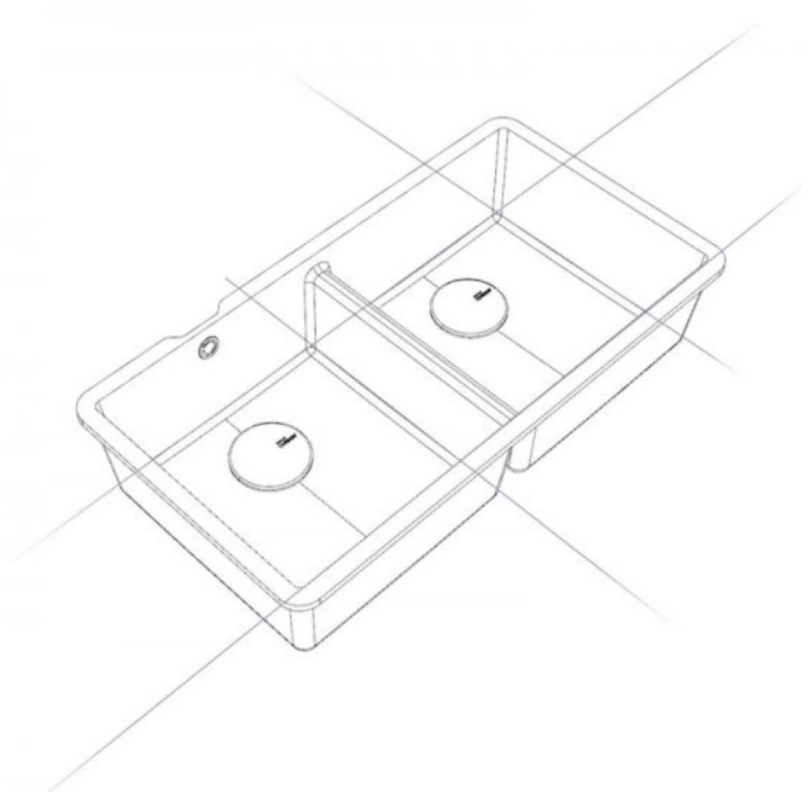

Corian® Colours: www.corian.uk/-colours-of-corian-r

Corian® Sink and Basin: www.corian.uk/-the-complete-residential-surfaces-solutions-

Corian® Bath and Showertray: www.corian.uk/-shower-trays-and-baths-

Technical Drawings and CAD: www.corian.uk/IMG/pdf/emea_technical_drawings.pdf

Corian® BIM Library Downloads: www.corian.uk/-bim-library-download-



SPECIFIC APPLICATIONS

KITCHEN WORKTOPS, ISLANDS AND WORKTOPS WITH SINKS

Horizontal surfaces of [12mm][19mm] thick, Corian® Solid Surface® by DuPont™, with edge details as indicated on the drawings.

Seams where more strength/heavy loads are placed on the surface must be reinforced with 50 mm wide reinforcement strip of 12 mm thick (6 mm if for vertical use sheet used is 6 mm) Corian® Solid Surface. Reinforcement strip must be fully bonded with Corian® Joint Adhesive.

[Vertical full height backsplash/cladding surfaces shall be of [6 mm][12 mm] thick Corian® Solid Surface with edge details as indicated on the drawings.]

[Upstand shall be of 12mm Corian® Solid Surface.]

Provide kitchen worktops,[upstand][backsplash][vertical cladding] with inconspicuous joints using Corian® Joint Adhesive supplied by DuPont™, joint size and type as indicated on the drawings.

Seal to worktop at any non-covered upstand, backsplash or cladding with [silicone][sealant] in clear or a colour matching/complimenting the colour of Corian®.
Worktop perimeter seal to wall with sealant to be confirmed as by Corian® Fabricator or decorator.

If needed complete with Corian® under mount sink.
Provide either single bowl or double bowl kitchen sink.

Corian® Worktop colour:

Corian® Worktop finish: [Matte] [Semi-Gloss] [Gloss]

Corian® Worktop nominal width:

Corian® Worktop nominal length:

Corian® Worktop nominal thickness:

Corian® Worktop expected metres of made worktop for project:

Sink 1 Model Number: (Corian® Sinks are CE marked EN 13310 and UKCA marked BS EN 13310)

Sink 2 Model Number: (Corian® Sinks are CE marked EN 13310 and UKCA marked BS EN 13310)

Corian® Sink colour:

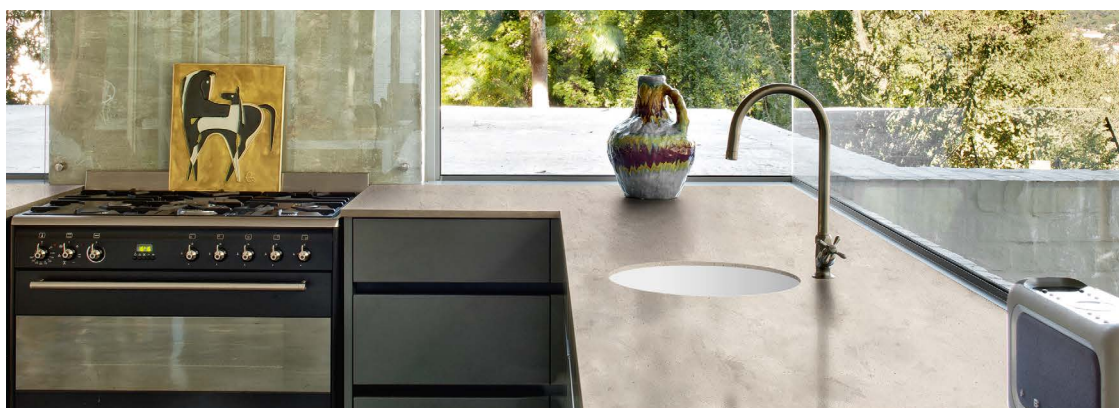



VANITY TOPS

Horizontal surfaces of [12 mm][19mm] thick, Corian® Solid Surface® by DuPont™, with edge details as indicated on the drawings. Complete with Corian® under mount vanity basin.

[Upstand shall be of 12mm Corian® Solid Surface.]

[Vertical cladding surfaces shall be of [6 mm][12 mm] thick Corian® Solid Surface with edge details as indicated on the drawings.]

Provide vanities with inconspicuous joints using Corian® Joint Adhesive supplied by DuPont™, joint size and type as indicated on the drawings.

Seal to worktop at any non-covered upstand/cladding with [silicone][sealant] in clear or a colour matching/complimenting the colour of Corian®.

Worktop perimeter seal to wall with sealant to be confirmed as by Corian® Fabricator or decorator.

Corian® Vanity top colour:

Corian® Vanity top finish: [Matte] [Semi-Gloss] [Gloss]

Corian® Vanity top dimension:

Corian® Vanity top expected metres of made Vanity top for project:

Corian® Basin Model Number: (Corian® Basins are CE marked EN 14688 and UKCA marked BS EN 14688)

Corian® Basin colour:





RECEPTION AREA STATIONS

Horizontal surfaces of [12 mm][19mm] thick Corian® Solid Surface by DuPont™ with edge details as indicated on drawings.

Provide worktops with inconspicuous joints using Corian® Joint Adhesive.

Seams where more strength/heavy loads are placed on the surface must be reinforced with 50 mm wide reinforcement strip of 12 mm thick (6 mm if for vertical use sheet used is 6 mm) Corian® Solid Surface. Reinforcement strip must be fully bonded with Corian® Joint Adhesive.

[Vertical cladding surfaces shall be of [6 mm][12 mm] thick Corian® Solid Surface with edge details as indicated on the drawings.]

[Provide vertical cladding with inconspicuous joints using Corian® Joint Adhesive supplied by DuPont™, joint size and type as indicated on the drawings.]

Seal to worktop at any non-covered upstand/cladding with [silicone][sealant] in clear or a colour matching/complimenting the colour of Corian®.

Worktop perimeter seal to wall with sealant to be confirmed as by Corian® Fabricator or decorator.

Corian® Colour:

Corian® Finish: [Matte] [Semi-Gloss] [Gloss]

Corian® Reception Station Dimension:

Silicone/sealant Colour:





LABORATORY AND HOSPITAL WORKTOPS

Horizontal surfaces of [12 mm][19mm] thick Corian® Solid Surface® by DuPont™, with edge details as indicated on the drawings. Seams where more strength/heavy loads are placed on the surface must be reinforced with 50 mm wide reinforcement strip of 12 mm thick (6 mm if for vertical use sheet used is 6 mm) Corian® Solid Surface. Reinforcement strip must be fully bonded with Corian® Joint Adhesive.

[Upstand shall be of 12mm Corian® Solid Surface.]

[Vertical cladding/backsplash surfaces shall be of [6 mm][12 mm] thick Corian® Solid Surface with edge details as indicated on the drawings.]

Provide laboratory and hospital worktops and/or vertical cladding with inconspicuous joints using Corian® Joint Adhesive supplied by DuPont™, joint size and type as indicated on the drawings.

Seal to worktop at any non-covered upstand/cladding with [silicone][sealant] in clear or a colour matching/complimenting the colour of Corian®.

Worktop perimeter seal to wall with sealant to be confirmed as by Corian® Fabricator or decorator.

If required complete with Corian® under mount sink or basin.

Provide either single bowl or double bowl kitchen sink or with basins.

Corian® Worktop colour:

Corian® Worktop finish: [Matte] [Semi-Gloss] [Gloss]

Corian® Worktop nominal width:

Corian® Worktop nominal thickness:

Corian® Worktop expected metres of made worktop for project:

Corian® Sink Model Number: (Corian® Sinks are CE marked EN 13310 and UKCA marked BS EN 13310)

Corian® Sink Colour:

Corian® Basin Model Number: (Corian® Basins are CE marked EN 14688 and UKCA marked BS EN 14688)

Corian® Basin colour:





TABLETOPS AND BAR TOPS

Horizontal tabletop surfaces of [12 mm][19 mm] thick, Corian® Solid Surface material by DuPont™, to size and shape, and with edge details as indicated on the drawings.

Provide tabletops with inconspicuous joints using Corian® Joint Adhesive. Seams where more strength/heavy loads are placed on the surface must be reinforced with 50 mm wide reinforcement strip of 12 mm thick (6 mm if for vertical use sheet used is 6 mm) Corian® Solid Surface. Reinforcement strip must be fully bonded with Corian® Joint Adhesive.

Corian® Tabletop Colour:

Corian® Tabletop Finish: [Matte] [Semi-Gloss] [Gloss]

Corian® Tabletop Dimension:

Corian® expected metres of made Tabletop for the project:

Bar tops in [12 mm][19 mm] thick Corian® Solid Surface by DuPont™, with edge details as indicated on the drawings. Provide bar tops complete with Corian® undermount sink. Provide bar tops with inconspicuous joints using Corian® Joint Adhesive.

Seams where more strength/heavy loads are placed on the surface must be reinforced with 50 mm wide reinforcement strip of 12 mm thick (6 mm if for vertical use sheet used is 6 mm) Corian® Solid Surface. Reinforcement strip must be fully bonded with Corian® Joint Adhesive.

Corian® Bar Top Colour:

Corian® Bar Top Finish: [Matte] [Semi-Gloss] [Gloss]

Corian® Bar Top Dimension:

Corian® expected metres of made Bar Top for the project:

Corian® Sink Model Number: (Corian® Sinks are CE marked EN 13310 and UKCA marked BS EN 13310)

Corian® Sink Colour:





COLD AND HOT COMMERCIAL FOOD SERVICES COUNTERS

Horizontal surfaces of [12 mm][19 mm] thick Corian® Solid Surface by DuPont™, with edge details as indicated on the drawings. Provide hot food service surfaces with inconspicuous joints using appropriate Corian® Joint Adhesive supplied by DuPont™. Seams in commercial applications must be reinforced with 50 mm wide reinforcement strip of 12 mm thick Corian® Solid Surface. Reinforcement strip must be fully bonded with Corian® Joint Adhesive.

Avoid Corian® temperatures above 65°C by providing insulation for appliances where necessary in/on worktops. Soft seams are also required between all adjacent hot and cold food wells to allow for the temperature differential. (It is also recommended that adjacent wells of opposite temperatures be at least 300 mm apart). Align the soft seam with a 3 mm gap. Fill the gap with colour complementing or clear flexible silicone/sealant. Soft seams may be covered with T-moulding or custom Corian® moulding if desired.

Consult your Corian® Design representative for further assistance.

Corian® Colour:

Corian® Finish: [Matte] [Semi-Gloss] [Gloss]

Corian® Counter Width:

Corian® Counter Dimension:

Corian® expected metres of made Counter for the project:

Silicone/Sealant Colour:





INTERIOR WALL CLADDING

Vertical surfaces shall be of [6 mm][12 mm] thick Corian® Solid Surface with edge details as indicated on the drawings. Provide vertical cladding with [inconspicuous joints using Corian® Joint Adhesive supplied by DuPont™][flexible seams using silicone sealant], joint size and type as indicated on the drawings.*

Fixing method to the wall must give freedom for expansion of 1 mm/m (or more depending on the expected temperature change ΔT). Mechanical sub construction or adhered with silicone or suitable flexible panel adhesive. A silicone/panel adhesive with 50% movement capability is recommended.

Perimeter edges sealed with [silicone][sealant] in clear or a colour matching/complimenting the colour of Corian® Solid Surface.** Perimeter edge seal to wall with [silicone][sealant] to be confirmed as by Corian® Fabricator or decorator.

Consult your Corian® Design representative for further assistance and detailed drawings.

Corian® Colour:

Corian® Finish: [Matte] [Semi-Gloss] [Gloss]

Corian® expected square metres of Interior Wall Cladding for the project:

Silicone/Panel Adhesive Type:

* The maximum dimension for the vertical cladding with inconspicuous joints using Corian® Joint Adhesive must be calculated taking into account the maximum temperature change (ΔT) and thickness of the adhesive. Please consult your Corian® Design representative.

** Several options are available for the corner solution and the perimeter seal dependant on the required expansion gap due to the maximum temperature change (ΔT) and length of the cladding panel. Please consult your Corian® Design representative.





INTERIOR WINDOW SILLS

Provide [12 mm] [19 mm] thick, Corian® Solid Surface by DuPont™ to size, shape, tolerances, and with edge details as indicated on the drawings.

Provide window sills with inconspicuous joints using appropriate Corian® Joint Adhesive supplied by DuPont™.

Corian® Window Sill Colour:

Corian® Window Sill Finish: [Matte] [Semi-Gloss] [Gloss]

Corian® Window Sill Dimension:

Corian® Window Sill expected square metres for project:





SHOWER WALLS

Provide [6 mm] [12 mm] thick panels of Corian® Solid Surface by DuPont™, applied to [existing, sound ceramic tile][moisture-resistant, gypsum wallboard] [cementitious board] with [butt joints] [reveal joints]. The joint size and type as indicated on the drawings. Use silicone sealant or suitable flexible panel adhesive to adhere panels to the substrate.

Hard seam with Corian® Joint Adhesive or cover strip/flexible options can be used between panel joints. Consult the technical team at Corian® for assistance in developing design details. For 6 mm sheet thickness hard seams must be reinforced with 6mm Corian® Solid Surface bonded fully with Corian® Joint Adhesive.

Provide panels to height as indicated on the drawings. Provide sloped or profiled top edge where panels stop short of the ceiling. Provide tooled silicone sealant joint top and bottom of panels and wherever panels adjoin adjacent materials.

Provide [clear] [coloured to compliment the Corian®] silicone/sealant for joints unless otherwise noted.

Corian® Shower Wall Colour 1:

Corian® Shower Wall Colour 2:

Corian® Shower Wall Finish: [Matte] [Semi-Gloss] [Gloss]

Corian® Shower Wall Panel sizes:

Corian® expected square metres for project:

Corian® Shower Tray Model:

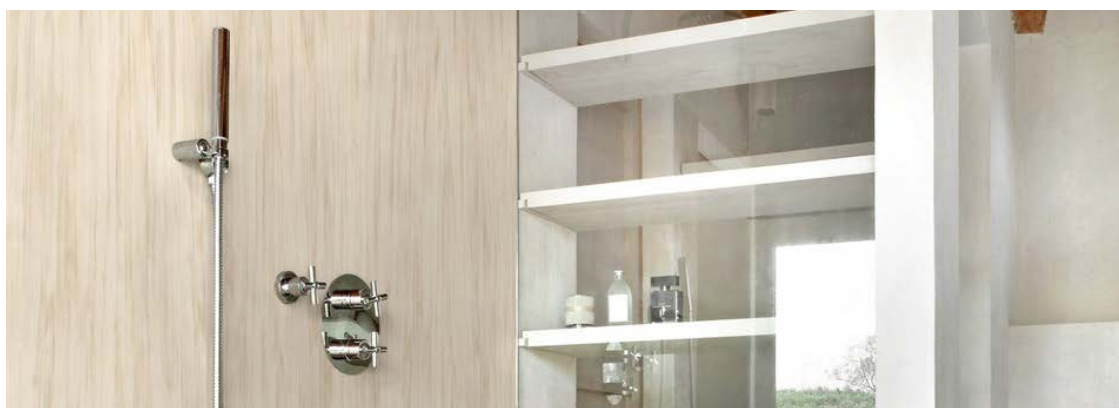



EXTERIOR CLADDING

ACRYLIC POLYMER COMPOSITE WALL PANEL MATERIAL

Material Composition: 1/3 Acrylic Resin (also known as Polymethyl Methacrylate or PMMA) and 2/3 of Aluminum Trihydrate (also known as ATH) filler and pigments/colorants

Manufacturer: Corian® Design business of DuPont de Nemours, Inc. , www.corian.com, www.dupont.com

Thickness: [12mm] [19mm (for specific applications)]

Size of the sheets: [760X3658X12mm] / [1300X3658X12mm] / [1500X3658X12mm]

Size of the module installed: [up to 5500X3500] with glued and reinforced panels

Finish: Provide panel with uniform finish characteristics: [Matte] / [Semi-Gloss] / [Gloss] / [Ridged] / [Thermoformed]

[Thermoform panels in shapes as indicated in Drawings.]

Colours as Standard: [Glacier White] [Designer White] [Bisque] [Cameo White] [Vanilla] [Deep Anthracite] [Deep Night Sky] [Deep Nocturne] [Deep Titanium]

Other Custom colours are available on demand

Joint type: [Overlap] [Open] [Seamed] , thermal expansion should be considered (3mm/m)

Fire rating: [Euroclass B,s1,d0]

Certification: [CSTB certified, “Avis Technique” including Seismic] [CE-Marked cladding solution, covered by an ETA under EAD 090062-00-0404 - Kits for External Wall Claddings Mechanically Fixed] [CWCT Certified]

The fabrication and installation of the panels shall be done in accordance to the technical guidelines as specified in the product bulletin: “DuPont™ Corian® as an external cladding solution” / Certifications

Material Warranty: Corian® panels installation has to be done by an authorized certified EC converter to be covered by the Corian® Solid surface Product warranty

The limited warranty applies only to defects appearing within ten (10) years from the date of permanent installation or twenty (20) years in the specific case of peeling, swelling and delaminating of Corian® Exterior Cladding panels.

Continue to **FIXING CORIAN® CLADDING PANELS** ►



EXTERIOR CLADDING

FIXING CORIAN® CLADDING PANELS

Corian® Exteriors panels are mechanically fixed to a durable (aluminum or Stainless steel) substructure fixed to the external wall of new or existing (retrofit) buildings.

Corian® Exteriors panels must be mounted on an adequate substructure with corrosion resistant fixings in such way the panels are not subject to any kind of tension and can move (expand and contract) freely, relative to one fixation point of each panel.

The substructure (fixing system) usually used to mount Corian® Exteriors panels is a mechanical fixing system based on an aluminum grid system, consisting of vertical profiles (L or T shape), mounted on brackets to connect to the wall. The substructure supplier has to check the substrate, according to official construction recommendations/regulations.

Façade consultant/Installers/Architects should provide static calculation. The calculation must be shown for the panel dimensions, fasteners, connectors, substructure, wall brackets, and anchoring.

Wall brackets are designed with both fixed and flexible points to allow for thermal expansion of the profile.

The cladding panels are hung on the horizontal profile by the clamps that are attached in a concealed (No through fastener) way to the panel with a specific undercut invisible fastener:

Keil Ref: 7.555.020.804 anchor AA Hs = 7mm

Other fasteners: suitability must be shown with a certification (i.e. SFS-TUF-S).

Number and location of fasteners: Consult with your sub-frame supplier for recommendations and details.

The facade structure must be built according to the construction details. The contractor must present a verifiable structural calculation and construction drawings before installation begins.

The thermal expansion of the panels must be taken into consideration. In order to avoid tension and possible cracking, the expansion gap (joint width) in the panel must be as large as the expected expansion (rule of thumb: 3mm /meter of panel in all directions)

Air gap: 20 mm minimum between the front of the insulation and the back of the rail.

Consult with your sub-frame supplier for recommendations and details.

Wall brackets and profiles have to be CE marked according to EN 1090 of alloy EN AW 6063 T66 , otherwise from a local source according nationally approved standards.





ADDITIONAL FEATURES

COVED AND SQUARE UPSTAND OR BACKSPLASH

COVED UPSTAND DETAIL

Vertical coved [upstand][backsplash] or side splash for surfaces of 12 mm thick Corian® Solid Surface with edge details as indicated on the drawings, complete with integral cove at base of backsplash or side splash. Provide standard radius cove at base of backsplash or side splash as detailed in the fabrication drawings. Provide coved detail with inconspicuous joints using appropriate Corian® Joint Adhesive, supplied by DuPont™ including all edges that adjoin other Corian® Solid Surface fabrications.

Corian® Colour:

Coved Upstand Height:

Coved Upstand expected metres in length required:

Coved Backsplash Height:

Coved Backsplash expected metres in length required:

SQUARE UPSTAND DETAIL

Vertical square [upstand][backsplash] or side splash of [6 mm][12 mm] thick Corian® Solid Surface with edge details as indicated on the drawings, complete with [silicone][sealant] seal where the detail meets the Corian® worktop surface.

Seal to worktop with [silicone][sealant] in clear or a colour matching/complimenting the colour of Corian®. Perimeter seal to wall with sealant to be confirmed as by Corian® Fabricator or decorator.

Provide [upstand][backsplash] to the required size with inconspicuous joints using appropriate Corian® Joint Adhesive, supplied by DuPont™.

Corian® Colour:

Square Upstand Height:

Square Upstand expected metres in length required:

Square Backsplash Height:

Square Backsplash expected metres in length required:



INLAYS

Custom inlaid vertical or horizontal surfaces of Corian® with design details, patterns and colour combinations as indicated on the drawings as per the design. Follow specific instructions for inlay procedures as detailed by DuPont™ Corian®, www.corian.com

Corian® Surface Colour:

Corian® Inlay Colour:

Corian® Inlay Position [Vertical Edge] [Horizontal Edge]

Corian® Inlay Width:



ENGRAVING

Custom vertical or horizontal surfaces of Corian® Solid Surface with engraved design details as indicated on the drawings. Engraving to be in the position shown in the drawings. Engraving to be carried out on the Corian® Surface [underside] [top side] as per the design.

Geometry and depth of the engraving can be limited depending on the application.

Please consult your Corian® Design representative.

Corian® Solid Surface Colour:



BACKLIGHTING

[Vertical 6 mm][Vertical 12 mm][Horizontal 12 mm][Horizontal and Vertical 12 mm] thick Corian® Solid Surface with [cut-outs][engraving] [painting][printing] for backlit application.

Fabricator to show examples of the intended effect for the specified Corian® Solid Surface colour with the specified light source in order to meet the client expectations for the backlit design.

Corian® Solid Surface Colour:

Note: A number of Corian® colours are ideal for backlit applications, however substrate shadowing may appear. Please discuss with your Corian® representative the possibilities and translucency options for your project.



THERMOFORMING

Custom formed [6mm] vertical or horizontal surfaces of [12 mm] [19mm] thick Corian® Solid Surface, with edge details, radii and connections to other Corian® Solid Surface fabrication elements as indicated on the design drawings.

Agreement on all custom thermoforming design details and thermoformed colour suitability required prior to forming moulds being produced for the custom design by the Corian® Fabricator.

Thermoformed Corian® Solid Surface Colour:



CORIAN® EDGE DETAIL EXAMPLES



Eased



Shark Nose



Full Bullnose



Double Eased



Square Return



Square



Waterfall Edge

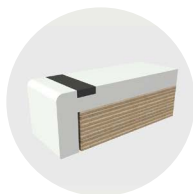

Corian® Top Inlay



Corian® Laminated Inlay



Setback



No Buildup



Half Bullnose



Spanish



Classic



Double Classic



Coved



Bevel



Double Bevel



UPSTAND AND BACKSPLASH EXAMPLES

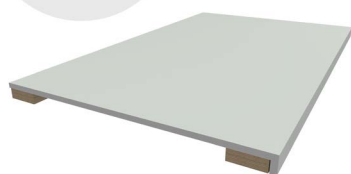

Surface Only

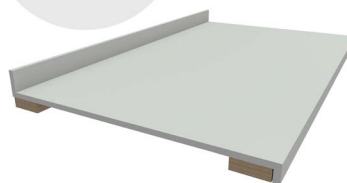

Square Upstand

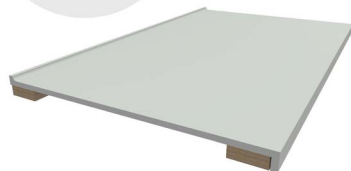

Coved Upstand

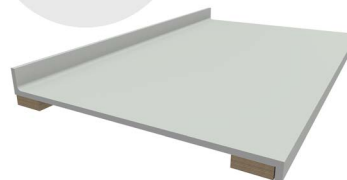

Coved Upstand

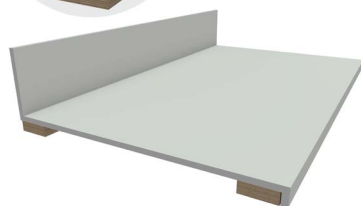

Square Backsplash

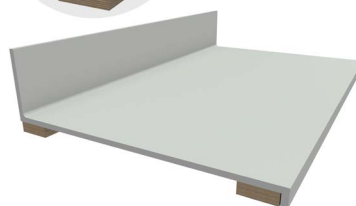

Coved Backsplash



ANNEXES (Example Drawings)

KITCHEN WORKTOPS, ISLANDS AND WORKTOPS WITH SINKS



Kitchen Worktop 3d View

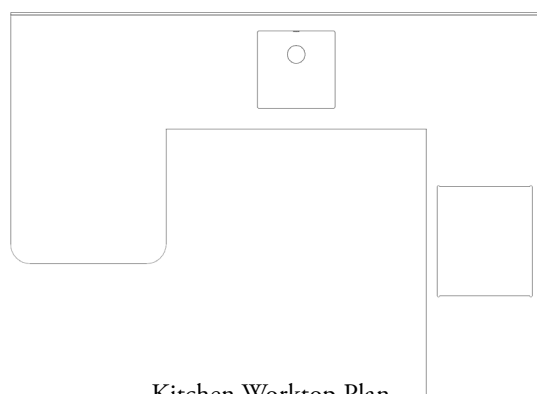

Kitchen Worktop Plan

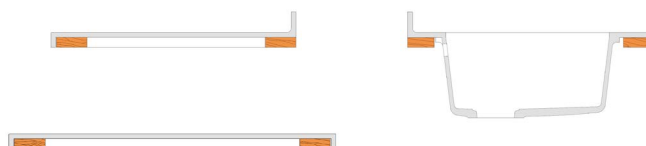

Kitchen Worktop Sectional



RECEPTION AREA STATIONS

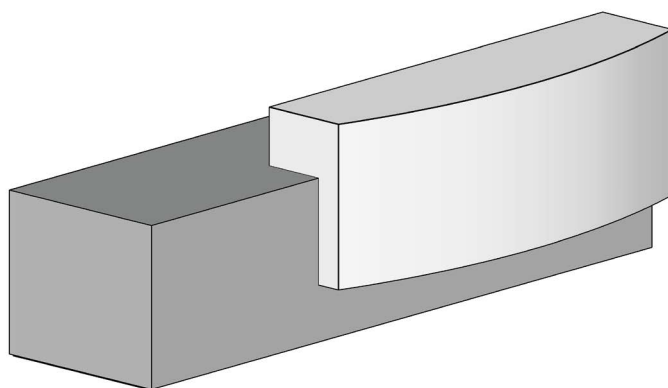
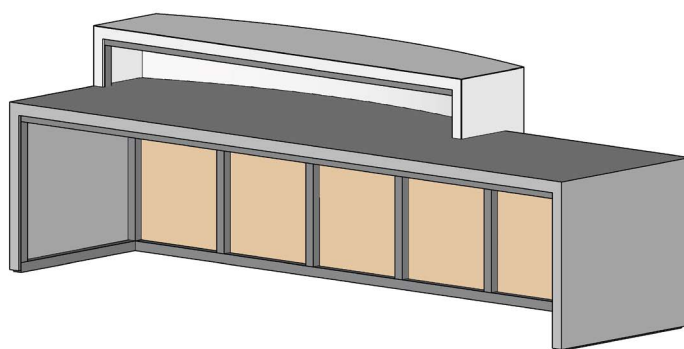

Reception Desk 3d View

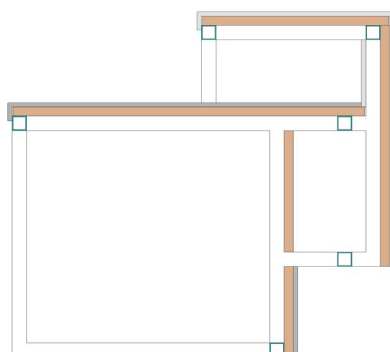

Reception Desk Sectional



LABORATORY AND HOSPITAL WORKTOPS

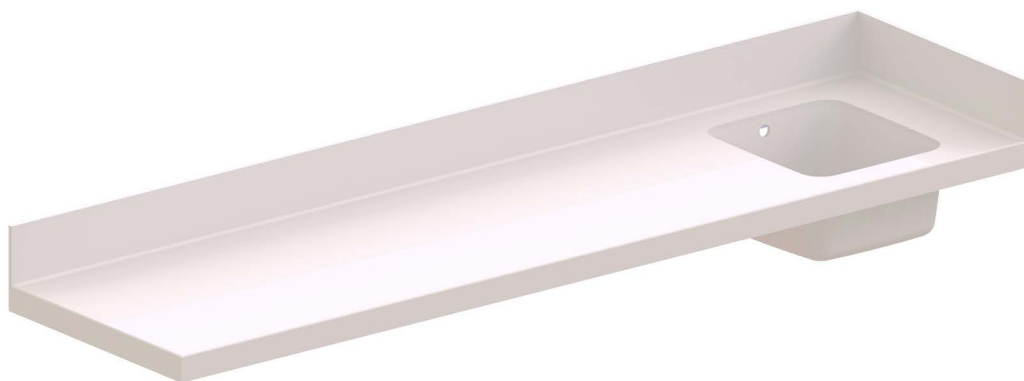

Laboratory Top 3d View

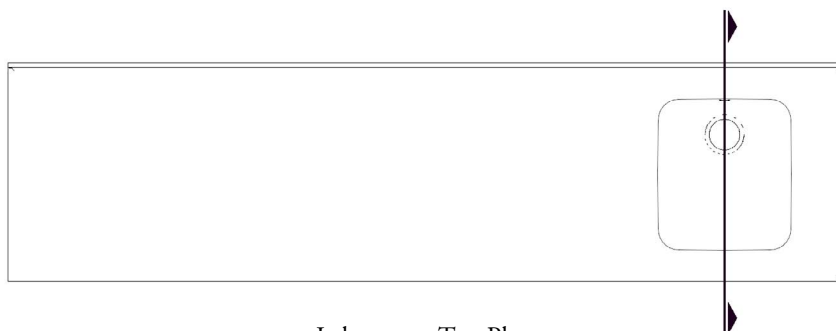

Laboratory Top Plan



Laboratory Top Sectional



VANITY TOPS

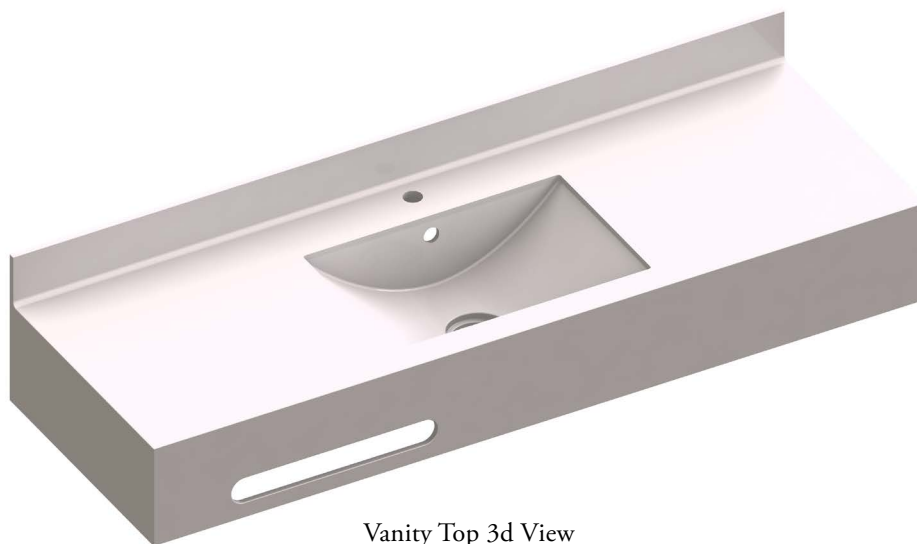

Vanity Top 3d View

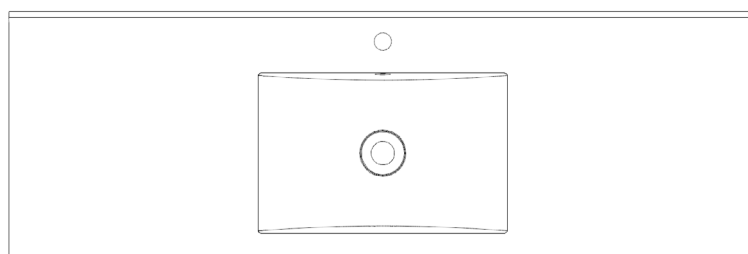

Vanity Top Plan

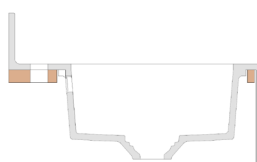

Vanity Top Sectional



TABLETOPS



Table 3d View

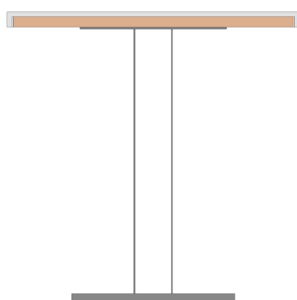

Table sectional



PLEASE VISIT OUR WEB SITE: WWW.CORIAN.UK OR CONTACT YOUR CORIAN® REPRESENTATIVE FOR MORE INFORMATION ABOUT CORIAN® SOLID SURFACE.

This information is based on technical data that DuPont de Nemours Inc. and its affiliates ("DuPont") believe to be reliable, and is intended for use by persons having technical skill and at their own discretion and risk. DuPont cannot and does not warrant that this information is absolutely current or accurate, although every effort is made to ensure that it is kept as current and accurate as possible. Because conditions of use are outside DuPont's control, DuPont makes no representations or warranties, express or implied, with respect to the information, or any part thereof, including any warranties of title, non-infringement of copyright or patent rights of others, merchantability, or fitness or suitability for any purpose and assumes no liability or responsibility for the accuracy, completeness, or usefulness of any information. This information should not be relied upon to create specifications, designs, or installation guidelines. The persons responsible for the use and handling of the product are responsible for ensuring the design, fabrication, or installation methods and process present no health or safety hazards. Do not attempt to perform specification, design, fabrication, or installation work without proper training or without the proper personal protection equipment. Nothing herein is to be taken as a license to operate under or a recommendation to infringe any patents. DuPont shall have no liability for the use of or results obtained from such information, whether or not based on DuPont's negligence. DuPont shall not be liable for (i) any damages, including claims relating to the specification, design, fabrication, installation, or combination of this product with any other product(s), and (ii) special, direct, indirect or consequential damages. DuPont reserves the right to make changes to this information and to this disclaimer. DuPont encourages you to review this information and this disclaimer periodically for any updates or changes. Your continued access or use of this information shall be deemed your acceptance of this disclaimer and any changes and the reasonableness of these standards for notice of changes.

Corian® and the Corian® logo system are registered trademarks or trademarks of affiliates of DuPont de Nemours, Inc. Copyright © 2023 DuPont. All rights reserved.